

POWERPLUS V3
POWERPLUS BIKE TRAINER
Quick Start Guide

TABLE OF CONTENTS

Knowing your V3	1
Package contents	1
Introduction of product appearance	2
Assembly descriptions	3
Assembling the POWERPLUS V3.....	3
Attaching the cassette (sold separately).....	4
Mounting your bicycle.....	5
Specifications	6
Safety precautions and regulations	7
Safety precautions before use.....	7
Notices	7
Disclaimer.....	8
Maintenance and care	8
Federal Communications Commission (FCC) Statement.....	8
CE Compliance Statement	9
POWERPLUS Limited Product Warranty Policy.....	9

KNOWING YOUR V3

Package contents

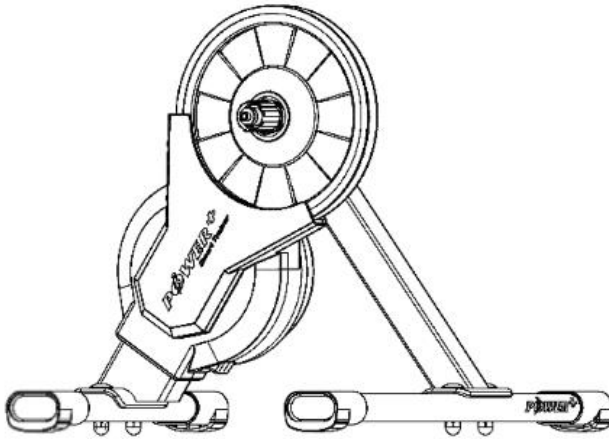

POWERPLUS V3 bike trainer main unit



Bolt x2 / Nut x2



Quick release kit



Open-end wrench



Power adapter

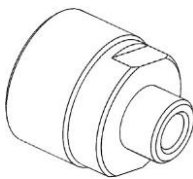

Adapter A –
for quick release
cassette nut

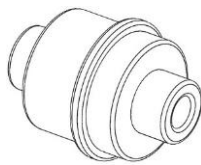

Adapter B –
for quick release
130mm/135mm

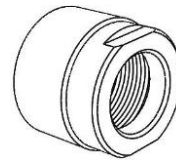

Adapter C –
for thru axle
cassette nut

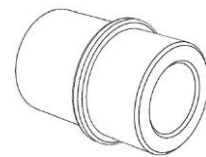

Adapter D –
for thru axle
12x142/
12x148mm

Note: Accessories may vary by country or region.

Introduction of product appearance

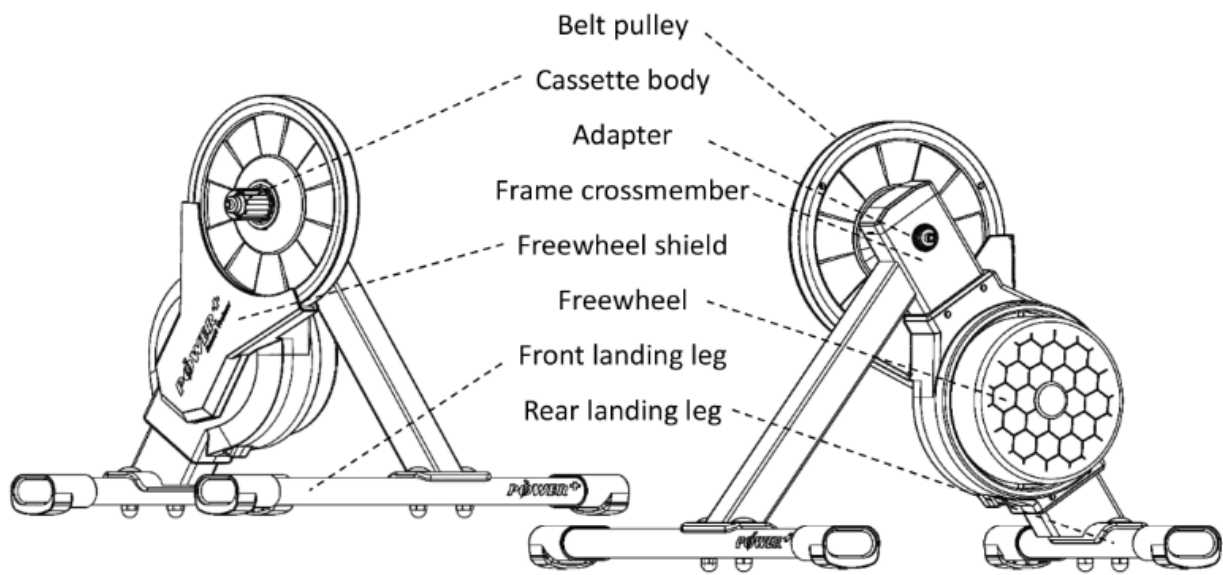

ASSEMBLY DESCRIPTIONS

Assembling the POWERPLUS V3

1. Flip the box and open the bottom of the box. Take the POWERPLUS V3 main unit and Styrofoam packaging out of the box at the same time.
2. Remove the front and rear bottom tubes from the sides of the Styrofoam packaging. (DO NOT open the Styrofoam packaging at both sides.)
3. Take out the bolts and insert them into the bolt holes on the main frame.
4. Put the front and rear bottom tubes on the main frame, then push the bolts into bolt holes.
5. Use the wrench to tighten the nuts.

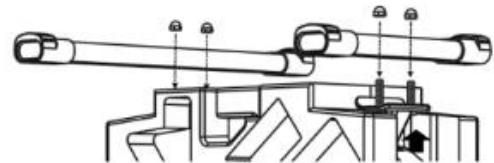
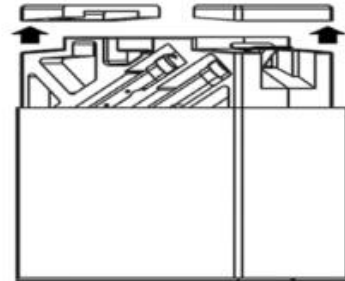

6. Flip the entire Styrofoam packaging to make the POWERPLUS V3 bike trainer stand upright on the floor where it will be used. Remove the Styrofoam packaging on both sides to complete assembly of the bike trainer.
7. Install the cassette (sold separately) into the cassette body and lock the cassette nut to prevent loosening.

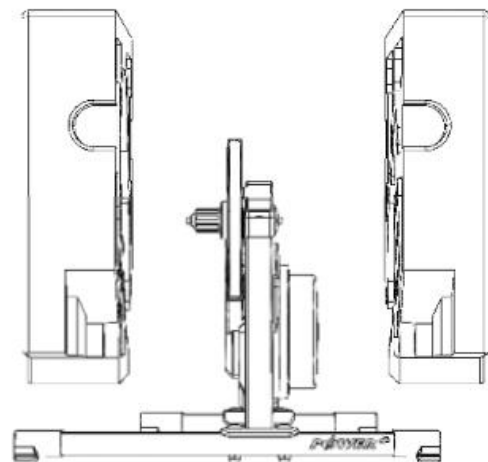

Attention:

The POWERPLUS V3 bike trainer cassette body is compatible with Shimano and SRAM cassette which can be directly installed with an 11-speed cassette. If you are using a non-11-speed cassette, please fit the cassette washer on the bottom of the cassette body first before installing the cassette.

Attaching the cassette (sold separately)

- **Attaching a compatible 11-speed cassette**

Attach the cassette onto the cassette body manually and use the cassette nut to secure it on the cassette body. Use the cassette removal socket to secure it tightly on the V3 cassette body (the tool is not included).

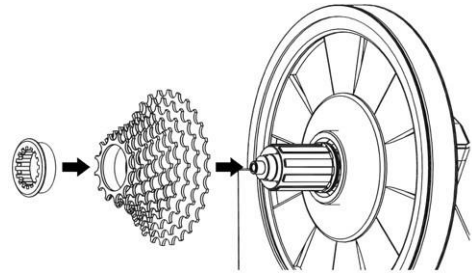

- **Attaching a 9-speed or 10-speed cassette**

Before attaching a 9-speed or 10-speed cassette, you need to put the 1.8mm cassette washer onto the cassette body first and then secure the cassette tightly on the V3 cassette body as mentioned above.

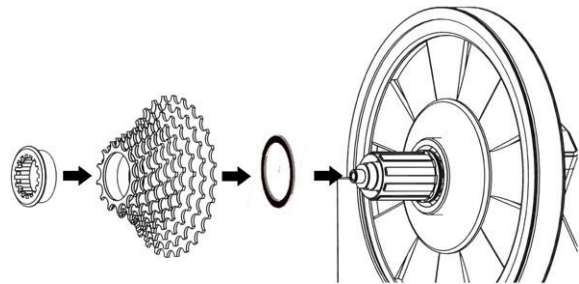

- **130mm or 135mm quick release installation**

When installing on a quick release bicycle frame, you need to use adapter A, adapter B and the quick release kit (these three accessories are included in the package). Please refer to the figure on the right for the installation.

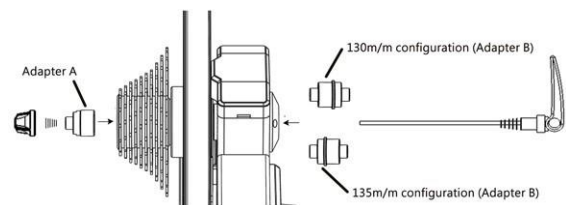

- **142mm or 148mm thru axle installation**

When installing on a thru axle bicycle frame, you need to use adapters C and D (the two accessories are included in the package). Please refer to the figure on the right for the installation.

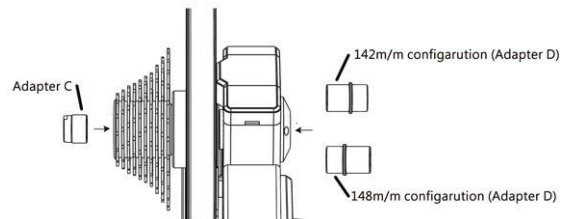

Mounting your bicycle

Shift the chain on your bicycle to the smallest sprocket of the cassette and then remove the rear wheel. Align the bicycle chain with the smallest sprocket of the cassette and then put on the chain as well as mount the bicycle on V3's axle to have the bicycle in a suitable position for riding.

Please use the bicycle quick release lever properly with care. When the arc of the rotating arm of the quick release lever is toward outside, it means the lever is in a released state. Rotate the rotating arm of the lever clockwise to tighten the quick release lever. The rotating arm of the quick release lever should be placed on the other side of the V3's cassette.

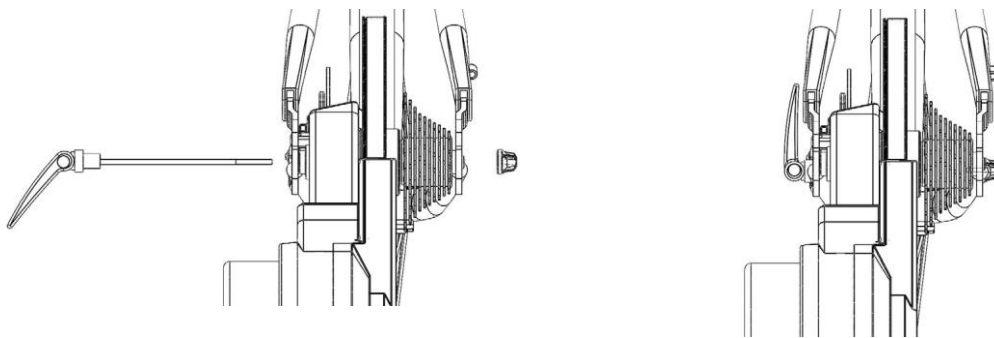

Please refer to the following figure for the installation of the thru axle bicycle. Insert the thru axle from the other side of the cassette and tighten the axle.

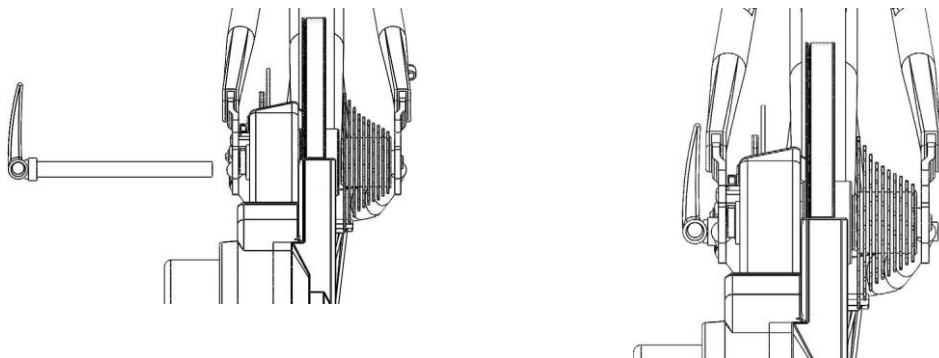

Attention:

1. Please firmly tighten the quick release lever and the thru axle to prevent damage to property or human body. If you cannot tighten the quick release lever and the thru axle, please contact your dealer or POWERPLUS customer service. Please DO NOT attempt to use the V3 in this situation.
2. When mounting the bicycle, please lift its front wheel and press the frame down to make the bicycle firmly mounted on the V3.

Indicator descriptions

When the bike trainer is powered on, the indicator will light red first to indicate that the control panel is conducting self diagnostics and auto zeroing. When the indicator is blinking green, it means the control panel has finished self diagnostics and auto zeroing and is entering standby mode to get ready for riding.

No.	Indicator status	Status description	Notice and remark
1	Red	Control panel self diagnostics and auto zeroing in progress	<ul style="list-style-type: none"> Normally, the process will complete in 2-4 seconds after it is powered on. Please DO NOT use the bike trainer before auto zeroing and self diagnostics are completed to avoid power measurement deviations.
2	Blinking green	Self diagnostics and auto zeroing completed	Can connect to software.
3	Solid green	Bluetooth is connected	Connected to a Bluetooth device and paired successfully.
4	Blue	The bike trainer is active and providing power normally	When connecting to Bluetooth or ANT+ devices, it will light blue during riding.

Specifications

Dimensions (installed)	620 x 518 x 453 mm
Total Weight (unboxed)	16.5 KG
Flywheel Weight	5.7 KG
Sound Level	52 dB
Max Power Output	2500 W
Max Simulated Incline	20%
Accuracy	±1.5%
Drivetrain	Cassette not included. Requires purchase/installation of new cassette: 8/9/10/11 Speed SRAM/Shimano
Connectivity	ANT+, ANT+ FE-C, and Bluetooth Smart
Firmware Upgradable	Yes
Electrical Requirements	100 - 240 Volt, 1.5 A, 50 Hz - 60 Hz
Box Dimensions	598 x 275 x 565 mm

SAFETY PRECAUTIONS AND REGULATIONS

Safety precautions before use

1. Specs of the POWERPLUS V3 power adapter are as follows:
 - Input: 100 ~ 240 VAC / 1.5 A
 - Output: 19 VDC / 4.7 A
 - Power plug: External diameter 5.5 m/m; internal diameter 2.5 m/m; length 10~12 m/m
2. Only use the power adapter certified by the POWERPLUS V3. Non-compliant power adapters will cause irreparable damage to the bike trainer.
3. When the bike trainer is active, please do not touch it and you should keep non users, animals or objects away from it to avoid danger.
4. Consult your coach before you start any training plans.
5. Please DO NOT put your hands or any object near the spinning parts of the POWERPLUS V3.
6. The flywheel/cassette of the POWERPLUS V3 might get hot after you use it for a while. Please DO NOT touch the flywheel/cassette within a short time.
7. Please DO NOT attempt to disassemble the bicycle when the cassette is running.
8. When you are using the POWERPLUS V3, keep your children and pets away from it to prevent injury.
9. The POWERPLUS V3 can only be installed and used on a firm, level ground.
10. When training is in progress, please ride safely.
11. Keep away from water.
12. Before training, you should check if the bicycle is firmly secured to the POWERPLUS V3.
13. The POWERPLUS V3 can only be used after it is completely assembled.
14. When using the POWERPLUS V3, you can only use accessories and power adapters certified by POWERPLUS.

Notices

1. POWERPLUS shall not be held responsible for users using software, applications and devices from other companies that result in malfunctioning of the POWERPLUS V3.
2. As ANT+™ and Bluetooth are mutually exclusive, it is impossible for the POWERPLUS V3 to send data simultaneously through ANT+™ or Bluetooth, i.e., when one of the protocols is in use, the POWERPLUS V3 will automatically stop the other protocol to avoid the possibility of causing V3 programs to misbehave.
3. Radio devices may cause interference and may change or completely prevent the POWERPLUS V3 from functioning normally. Therefore, when training using the V3, it is advised to stay away from high voltage power lines, traffic signals, railway power lines, buses or trams.

4. When the POWERPLUS V3 is not in use, make sure not to expose it to direct sunlight for long periods of time.

Disclaimer

Attention! POWERPLUS shall not be held responsible for temporary or permanent injury to the user out of using the POWERPLUS V3 (either directly or indirectly).

Maintenance and care

1. When cleaning the bike trainer, please use neutral lubrication oil. DO NOT use corrosive detergents.
2. DO NOT burnish the surface of the bike trainer or drill holes. Scratches or drilled holes will lead to occurrence of cracks.
3. Please place the bike trainer indoors and keep it dry to avoid damage from humidity.

Federal Communications Commission (FCC) Statement

This device complies with part 15 of the FCC Rules. Operation is subject to the following two conditions: (1) This device may not cause harmful interference, and (2) this device must accept any interference received, including interference that may cause undesired operation.

Changes or modifications not expressly approved by the party responsible for compliance could void the user's authority to operate the equipment.

This equipment has been tested and found to comply with the limits for a Class B digital device, pursuant to part 15 of the FCC Rules. These limits are designed to provide reasonable protection against harmful interference in a residential installation. This equipment generates, uses and can radiate radio frequency energy and, if not installed and used in accordance with the instructions, may cause harmful interference to radio communications. However, there is no guarantee that interference will not occur in a particular installation. If this equipment does cause harmful interference to radio or television reception, which can be determined by turning the equipment off and on, the user is encouraged to try to correct the interference by one or more of the following measures:

- Reorient or relocate the receiving antenna.
- Increase the separation between the equipment and receiver.
- Connect the equipment into an outlet on a circuit different from that to which the receiver is connected.
- Consult the dealer or an experienced radio/TV technician for help.

This device complies with radio frequency (RF) exposure limits adopted by the Federal Communications Commission for an uncontrolled environment. This equipment should be installed and operated to ensure a minimum of 20 cm spacing to any person at all times.

CE Compliance Statement

2402 MHz ~ 2480 MHz, power: -0.81 dBm

This device meets the EU requirements and the International Commission on Non-Ionizing Radiation Protection (ICNIRP) on the limitation of exposure of the general public to electromagnetic fields by way of health protection. This equipment should be installed and operated to ensure a minimum of 20 cm spacing to any person at all times.



Waste Electrical and Electronic Equipment (WEEE)

This symbol means that according to local laws and regulations your product and/or its battery shall be disposed of separately from household waste. When this product reaches its end of life, take it to a collection point designated by local authorities. Proper recycling of your product will protect human health and the environment.

Hereby, POWERPLUS Inc. declares that the radio equipment type bike power trainer is in compliance with Directive 2014/53/EU.

The full text of the EU declaration of conformity is available at the www.POWERPLUS.com

POWERPLUS Limited Product Warranty Policy

This Limited Product Warranty shall apply to POWERPLUS products including all accessories as contained within the original POWERPLUS gift box. POWERPLUS warrants that products from its authorized distributors and retailers will meet the applicable product specifications and be free from all defects in material and workmanship during the Limited Product Warranty Period, **one year** starting from the date of original purchase, if the products are used and serviced in accordance with the user manual and other documentation provided to the purchaser at the time of purchase. This Limited Product Warranty is subjected to the following terms and conditions:

1. To obtain warranty service, a proof of purchase, an original or copy of the sales receipt from the original retailer, is required.
2. This Limited Product Warranty is only valid and enforceable in the country/region where the product is sold.
3. This Limited Product Warranty is at sole option of POWERPLUS to either repair or replace the defective product during the Limited Product Warranty Period. POWERPLUS will not replace missing components from any package purchased through online auctions.
4. To obtain warranty service, contact your local POWERPLUS authorized retailer or POWERPLUS for shipping instructions and an RMA number.
5. This Limited Product Warranty covers expenses for inspecting and repairing the product during the Limited Product Warranty Period. The defective product shall be delivered by the purchaser at his/her own expense to the designated premises together with the proof of purchase and RMA number.
6. POWERPLUS will return the repaired or replaced product to the drop-zone for collection by the customer in good working condition. All replaced faulty products or components will become the property of POWERPLUS.

If POWERPLUS repairs or replaces the product, the repaired or replaced product shall continue to be warranted for the remaining time of the original warranty period or for three (3) months from the date of repair or replacement, whichever is longer.

7. Before returning any units for service, be sure to back up data and remove any confidential, proprietary, or personal information from the Product. POWERPLUS is not responsible for damage to or loss of data.
8. POWERPLUS reserves the right to add, delete or amend the terms and conditions at any time without prior notice on its website indicated below.
9. **THIS LIMITED WARRANTY SHALL NOT APPLY IF THE DAMAGE WAS CAUSED BY ANY OF THE FOLLOWING:**
 - A. The product serial number has been removed, erased, defaced, altered or is illegible.
 - B. The damage is resulting from the use of the product in a manner other than its normal and customary manner.
 - C. Deterioration of the product due to normal wear and tear.
 - D. The damage is arising from improper installation, unauthorized repair, alteration or modification to this product by third parties other than POWERPLUS or its designee.
 - E. The damage is arising from operating with components or accessories not officially authorized or provided by POWERPLUS or used in other than its intended use.
 - F. The damage is arising from exposure to abnormally corrosive conditions or operation with extreme heat or humidity.

10 POWERPLUS WILL NOT BE LIABLE FOR INCIDENTAL OR CONSEQUENTIAL LOSSES OR DAMAGES TO ANY NATURE, INCLUDING BUT NOT LIMITED TO LOST PROFITS OR COMMERCIAL LOSS, TO THE FULLEST EXTENT THAT THOSE LOSSES OR DAMAGES CAN BE DISCLAIMED BY LAW.

11. This Limited Product Warranty does not affect the customer's statutory rights in law specific to the country of purchase, such rights remain protected. Some countries do not allow the exclusion or limitation of incidental or consequential loss or damage, or limitation of the implied warranties, in those circumstances the preceding limitation of exclusions may not apply to such customers.

Warranty Coverage:

1. Under normal conditions of use, the product main unit and components gets a one year free after-sales maintenance services.
2. Please present the original purchase approval or receipt with this Product Warranty on upon of requesting a service. Service fee might be charged in accordance with this Product Warranty.

Please note the Limited Product Warranty Period and service availability and response times may vary from country to country and may also be subject to registration requirement in the country of purchase. If you require assistance regarding warranty conditions, or any other enquiries, please contact the original retailer or POWERPLUS.

Website: <https://www.powerplusco.com>

V3 BIKE POWER TRAINER
Product Warranty

Please retain the original purchase receipt or approval in order to protect your right of free warranty service.

	Serial Number
	Purchase Date
	Dealer stamps

Thank you again for purchasing the POWERPLUS V3.

POWERPLUS reserves the right to design, change specifications, and improve quality.